

CDA

DUAL IMPELLER CENTRIFUGAL ELECTRIC PUMPS

in cast iron



Cast iron dual impeller centrifugal electric pumps.

APPLICATIONS

- Pressure boosting domestic plants
- Small-scale irrigation
- Pumping non-aggressive liquids for civil and industrial use
- Washing plants
- Washing vehicles

TECHNICAL DETAILS

- Available with brass impeller (CDA 0.75 M GO, CDA 1.00 M/T GO)
- They can be inserted into machinery for industrial use

PUMP TECHNICAL DATA

- Maximum working pressure: 6 bar for CDA 0.75 - 1.00, 10 bar for the rest of the range
- Maximum temperature of the liquid: 40°C for CDA 0.75 - 1.00, 90°C for the rest of the range
- Suction connection G1 for CDA 0.75 - 1.00, G1¼ for CDA 1.50 - 2.00 - 3.00, G1½ for CDA 4.00 - 5.50
- Discharge connection: G1 for CDA 0.75 - 1.00 - 1.50 - 2.00 - 3.00, G1¼ for CDA 4.00 - 5.50

MOTOR TECHNICAL DATA

- IE3 high energy-efficiency motors starting from 0.75kW
- Self-ventilated 2 pole asynchronous motor
- Class of insulation F
- IP44 Protection degree
- 230V ± 10% 50Hz single phase voltage, 230/400V ± 10% 50Hz three phase voltage
- Permanent capacitor inserted and thermo-amperometric protection with automatic rearm incorporated for the single phase motor
- Protection under user's responsibility for the three phase version

MATERIALS

- Cast iron pump casing
- Mechanical seal in Ceramic/Carbon/NBR
- Impeller in PPE + PS reinforced with glass fibres for CDA 0.75-1.00, in brass for the rest of the range
- Shaft in AISI 303 for CDA 0.75 - 1.00 - 1.50 - 2.00 - 3.00, in AISI 304 for CDA 4.00 - 5.50
- Bracket in aluminium for CDA 0.75-1.00, in cast iron for the rest of the range
- Seal housing disc in AISI 304 for CDA 0.75-1.00, in cast iron built-in the motor bracket for the rest of the range

ACCESSORIES (On request)

- Electric panels
- Vessels
- Floats
- Pressure switches
- Presscomfort - Pressure regulator
- E-power - Variable speed control system
- E-drive - Variable speed control system

PERFORMANCE CURVES (according to ISO 9906 Attachment A)

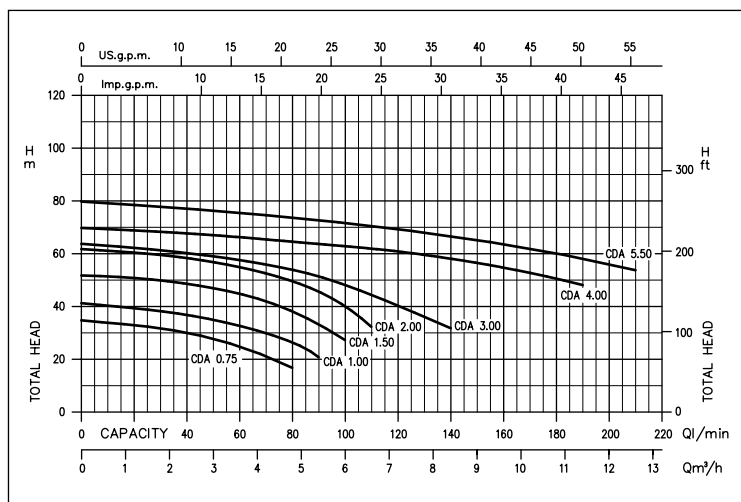

IDENTIFICATION CODE

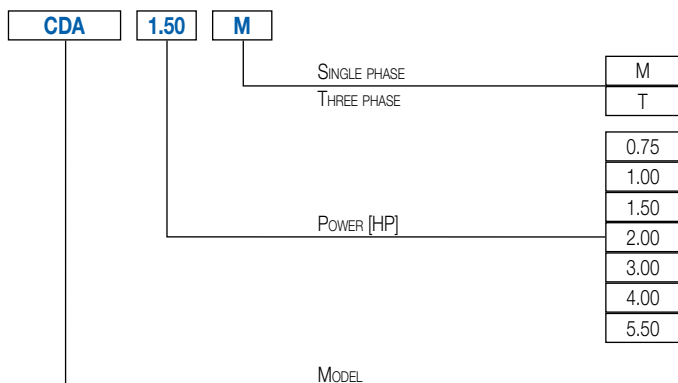

DUAL IMPELLER CENTRIFUGAL ELECTRIC PUMPS

in cast iron

PERFORMANCE CHART

Single phase 230V	Model Three phase 230/400V	P ₂		Q = Flow Rate																					
		[HP]	[kW]	l/min m ³ /h	20 1.2	40 2.4	50 3	80 4.8	90 5.4	100 6	110 6.6	140 8.4	170 10.2	190 11.4	210 12.6										
				H=Head [m]																					
CDA 0.75 M	CDA 0.75 T	0.75	0.55	33.0	30.2	27.9	17.0	-	-	-	-	-	-	-	-	-	-	-	-	-	-	-	-	-	
CDA 1.00 M	CDA 1.00 T	1	0.75	39.5	37.0	35.2	27.0	21.0	-	-	-	-	-	-	-	-	-	-	-	-	-	-	-	-	-
CDA 1.50 M	CDA 1.50 T	1.5	1.1	50.8	48.8	47.1	38.4	33.4	27.5	-	-	-	-	-	-	-	-	-	-	-	-	-	-	-	-
CDA 2.00 M	CDA 2.00 T	2	1.5	60.5	58.6	56.9	49.8	46.5	40.3	32.5	-	-	-	-	-	-	-	-	-	-	-	-	-	-	-
-	CDA 3.00 T	3	2.2	-	60.5	59.3	54.1	51.6	48.4	44.6	32.0	-	-	-	-	-	-	-	-	-	-	-	-	-	-
-	CDA 4.00 T	4	3	-	-	67.0	64.8	63.9	62.5	62.0	58.0	53.5	48.0	-	-	-	-	-	-	-	-	-	-	-	-
-	CDA 5.50 T	5.5	4	-	-	76.5	73.9	72.9	71.8	70.5	66.8	62.0	58.3	54.0	-	-	-	-	-	-	-	-	-	-	-

DIMENSIONS

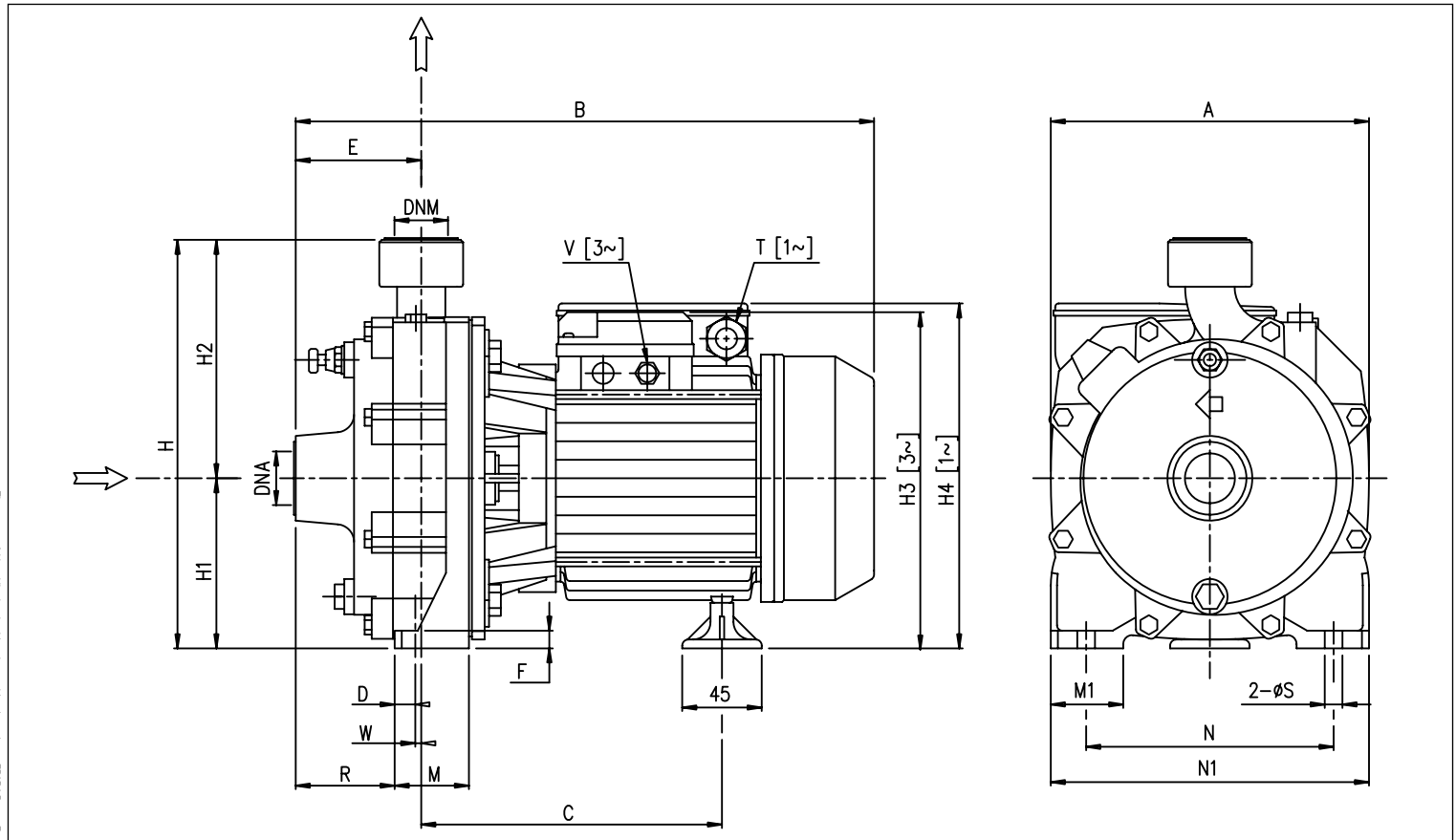

DIMENSIONAL TABLE

Modello	Dimensioni [mm]																				Peso [kg]		
	A	B	C	D	E	F	H	H1	H2	H3 [1]	H4 [2]	M	M1	N	N1	R	T [2]	V [1]	W	S		DNA	DNM
CDA 0.75M	183	336.3	179.8	8.3	73	9	227	97	130	-	198	42	40	140	180	57,5	PG11	-	6,8	9,5	G1	G1	13,8
CDA 0.75T	183	336.3	179.8	8.3	73	9	227	97	130	197,5	-	42	40	140	180	57,5	-	PG11	6,8	9,5	G1	G1	13,8
CDA 1.00M	183	336.3	179.8	8.3	73	9	227	97	130	-	198	42	40	140	180	57,5	PG11	-	6,8	9,5	G1	G1	15,0
CDA 1.00T	183	336.3	179.8	8.3	73	9	227	97	130	197,5	-	42	40	140	180	57,5	-	M16x1.5	6,8	9,5	G1	G1	15,0
CDA 1.50M	209	407.8	218.3	8.3	86	9	265	110	155	-	242	48	40	155	195	65,5	PG13,5	-	12,3	9,5	G1¼	G1	24,2
CDA 1.50T	194	419.8	218.3	8.3	86	9	265	110	155	224	-	48	40	155	195	65,5	-	M20x1.5	12,3	9,5	G1¼	G1	25,8
CDA 2.00M	209	410.8	218.3	8.3	86	9	265	110	155	-	242	48	40	155	195	65,5	PG13,5	-	12,3	9,5	G1¼	G1	26,0
CDA 2.00T	194	420.5	218.3	8.3	86	9	265	110	155	224	-	48	40	155	195	65,5	-	M20x1.5	12,3	9,5	G1¼	G1	28,0
CDA 3.00T	194	423.3	218.3	8.3	86	9	265	110	155	224	-	48	40	155	195	65,5	-	M20x1.5	12,3	9,5	G1¼	G1	26,7
CDA 4.00T	228	494.5	262.5	12	95.5	12	308.5	133.5	175	259.5	-	57	50	180	230	71.5	-	M20x1.5	12	12	G1½	G1¼	46.8
CDA 5.50T	228	508	225.3	12	95.5	12	308.5	133.5	175	264.5	-	57	50	180	230	71.5	-	M20x1.5	12	12	G1½	G1¼	52.0

[1]= Three-phase only

[2]= Single phase only

DUAL IMPELLER CENTRIFUGAL ELECTRIC PUMPS

in cast iron

SECTIONAL VIEW

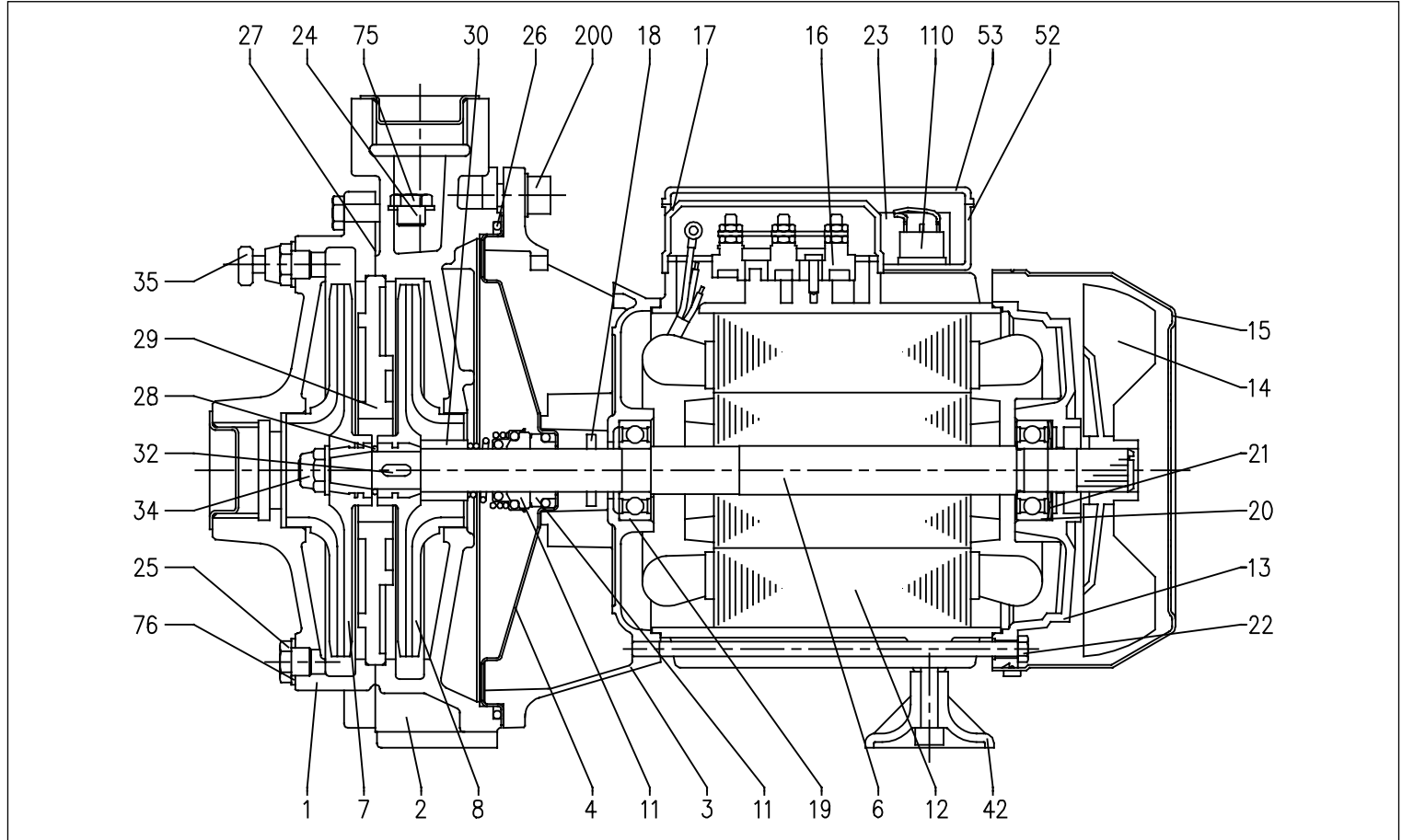

MATERIALS TABLE

Ref.	Name	Materials	Ref.	Name	Materials
1	Pump casing	Cast iron	23	Capacitor [2]	-
2	Pump casing	Cast iron	24	Plug	Brass
3	Motor bracket	[3]	25	Plug	Brass
4	Casing cover	[4]	26	O-Ring	NBR
6	Shaft	[5]	27	Pump body gasket	Cellulose fibres included
7	Impeller	[6]	28	O-Ring	NBR
8	Impeller	[6]	29	Intermediate disc	Cast iron
11	Mechanical seal	Ceramic/Carbon/NBR	30	Seal spacer	Brass
12	Motor frame	-	32	Key	AISI 316
13	Motor cover	Aluminium	34	Impeller nut [7]	AISI 304
14	Fan	PP	35	Bleed valve	Brass
15	Fan cover	Galvanised Fe P04	42	Motor support	PP
16	Terminal Box	-	52	Capacitor-holder box [2]	ABS
17	Terminal Box cover [1]	Aluminium	53	Capacitor-holder box cover [8]	ABS
18	Splash ring	NBR	75	Washer	Aluminium
19	Bearing (pump side)	-	76	Washer	Aluminium
20	Bearing (motor side)	-	110	Motor protector [9]	-
21	Adjustment ring	Steel C70	200	Screw (pump body)	Zn. steel Cl. 8.8 ISO 898-1
22	Tie-rod	Galvanised Fe 42			

[1]= Three-phase only

[2]= Single phase only

[3]= Aluminium for CDA 0.75 - 1.00, cast iron for the rest of the range

[4]= AISI 304 for CDA 0.75 - 1.00, cast iron integrated Motor support for the rest of the range

[5]= AISI 303 (part in contact with the liquid) for CDA 0.75 - 1.00 - 1.50 - 2.00 - 3.00, AISI 304 (part in contact with the liquid) for the rest of the range

[6]= PPE+PS reinforced with fibreglass for CDA 0.75 - 1.00, brass for the rest of the range

[7]= Version with brass impeller only

[8]= With gasket in NBR only for CDA 0.75 - 1.00 single phase models

[9]= Version CDA 1.50 - 2.00 single phase only

DUAL IMPELLER CENTRIFUGAL ELECTRIC PUMPS

in cast iron

MECHANICAL SEAL

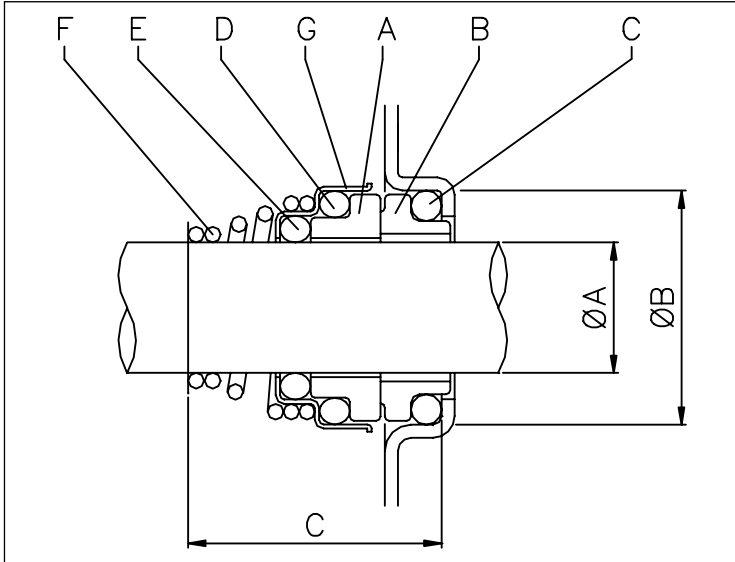

MATERIALS TABLE

Ref.	Name	Materials
A	Rotating part	Ceramic
B	Fixed part	Carbon
C	O-Ring	NBR
D	O-Ring	NBR
E	O-Ring	NBR
F	Spring	AISI 316
G	Structure/frame	AISI 304

DIMENSIONS

Single phase	Three phase	ØA	ØB	C
CDA 0.75 M	CDA 0.75 T	15	26	29
CDA 1.00 M	CDA 1.00 T	15	26	29
CDA 1.50 M	CDA 1.50 T	18	30.9	32
CDA 2.00 M	CDA 2.00 T	18	30.9	32
-	CDA 3.00 T	18	30.9	32
-	CDA 4.00 T	20	30.9	33
-	CDA 5.50 T	20	30.9	33

ELECTRIC DATA TABLE

Model	Single phase 230V	Three phase 230/400V	P ₂		Efficiency		Capacitor		Efficiency (%)			P ₁		Absorbed Current		
			[HP]	[kW]	Single phase	Three phase	Single phase µF	V _c	Three phase η %			Single phase [kW]	Three phase [kW]	Single phase 230V	[A]	
									50%	75%	100%				230V	300V
CDA 0.75 M	CDA 0.75 T		0,75	0,55	-	-	16	450	-	-	-	1,1	1,05	5,0	3,4	2,0
CDA 1.00 M	CDA 1.00 T		1	0,75	-	IE3	20	450	80,9	82,3	82,1	1,38	0,91	6,1	3,0	1,7
CDA 1.50 M	CDA 1.50 T		1,5	1,1	-	IE3	40	450	83,0	85,8	85,6	1,85	1,77	8,6	5,8	3,3
CDA 2.00 M	CDA 2.00 T		2	1,5	-	IE3	40	450	84,2	86,8	86,9	2,35	2,01	10,8	7,1	4,1
-	CDA 3.00 T		3	2,2	-	IE3	-	-	86,2	87,0	86,0	-	2,55	-	8,2	4,7
-	CDA 4.00 T		4	3	-	IE3	-	-	85,9	87,5	87,1	-	3,44	-	11,1	6,4
-	CDA 5.50 T		5,5	4	-	IE3	-	-	85,8	88,3	88,4	-	4,52	-	15,1	8,7

NOISE DATA TABLE

Model	Single phase 230V	Three phase 230/400V	P ₂		L _{pa} - dB(A)*
			[HP]	[kW]	
CDA 0.75 M	CDA 0.75 T		0,75	0,55	<70
CDA 1.00 M	CDA 1.00 T		1	0,75	
CDA 1.50 M	CDA 1.50 T		1,5	1,1	
CDA 2.00 M	CDA 2.00 T		2	1,5	
-	CDA 3.00 T		3	2,2	
-	CDA 4.00 T		4	3	
-	CDA 5.50 T		5,5	4	

* Mean value of several measurements at 1 m distance around the pump.
Tolerance ± 2.5 dB.