



Stainless Steel Pumps

Model 2CDX Twin Impeller Pumps



Stainless steel twin impeller centrifugal pumps. Featuring the one piece volute manufactured using Ebara's unique plasma stamping process.

Specifications

- Twin impeller centrifugal pump, closed impellers
- Maximum working pressure: 8 bar
- Maximum liquid temperature: 60 °C

Materials

- Pump casing & casing cover: 304 Stainless Steel
- Impeller: 304 Stainless Steel
- Diffuser: 304 Stainless Steel
- Shaft: 304 Stainless Steel (wetted part)
- Bracket: Aluminium (upto 1.5 kW) Cast Iron (2.2 kW & above)
- Motor frame: Aluminium
- Mechanical seal: Carbon/Ceramic/NBR

Motor Data

- TEFC, 2 pole, 50 Hz
- Insulation class F
- IP55 protection
- 1 Phase - 230 Volt
- 3 Phase - 230/400 Volt (dual voltage motors)
- In built overload protection for 1 Phase

Range

- 25 mm Ø discharge
- 0.75 to 1.5 kW - 1 Phase
- 0.75 to 3.7 kW - 3 Phase

Supply

- 1.8 m cable with 3 pin plug (1 Phase models only)

Options

- High temperature seal (110 °C)
(Carbon/Ceramic/Viton seal, Viton O' Rings)
- Hard faced seal (SiC/SiC/Viton seal, Viton O' Rings)

Performance Curve

Synchronous Speed: 3000 rpm

Water temp: 20 °C

Applicable standard of test : ISO 9906 Annex A

Model Code

2CDXM 120/12
 Motor Size (e.g. 12 = 1.2 HP)
 Nominal Capacity (70, 120 or 200 lpm)
 Model 2CDX = 3 Phase
 2CDXM = 1 Phase
 (M - Monophase)

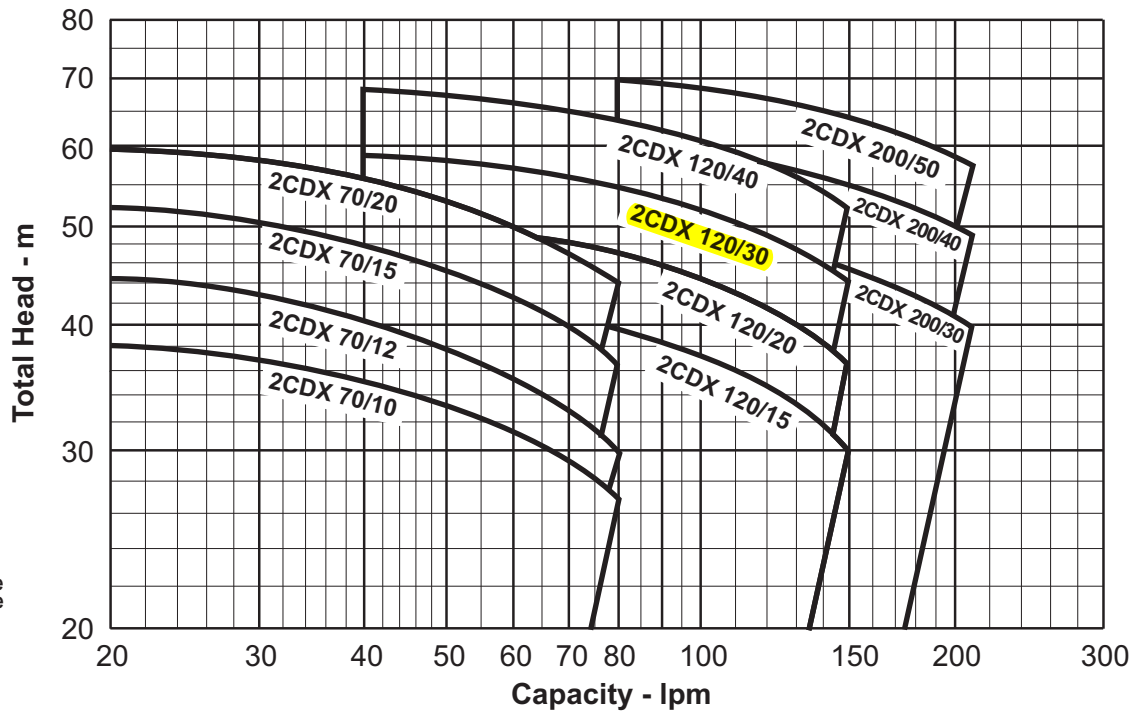

Performance Table

Pump Model	Motor Output	Discharge/Suction Ø mm	Full Load Current		Capacitor (1 Phase models only)	Capacity - lpm										
			1 Phase 230 V	3 Phase 400 V		20	40	60	Total Head - m				180	210		
2CDXM / 2CDX 70/10	0.75 kW	25 / 32 mm	6.0 A	2.0 A	20 µF	38.5	35.3	31.5	27							
2CDXM / 2CDX 70/12	0.9 kW	25 / 32 mm	7.0 A	2.5 A	31.5 µF	44.5	40.3	35.3	30							
2CDXM / 2CDX 70/15	1.1 kW	25 / 32 mm	8.1 A	3.2 A	40 µF	52.5	48	42.8	36.5							
2CDXM / 2CDX 70/20	1.5 kW	25 / 32 mm	10.0 A	4.3 A	40 µF	60	55.6	50.4	44							
2CDXM / 2CDX 120/15	1.1 kW	25 / 32 mm	8.3 A	3.2 A	40 µF		42	41	39.5	35	30					
2CDXM / 2CDX 120/20	1.5 kW	25 / 32 mm	10.2 A	4.3 A	40 µF		51.5	49.5	47.4	41.8	36.5					
2CDX 120/30	2.2 kW	25 / 32 mm	—	5.1 A	—		59	57	54.6	49.2	44					
2CDX 120/40	3.0 kW	25 / 32 mm	—	6.1 A	—		68.5	66.5	64	58	52					
2CDX 200/30	2.2 kW	25 / 40 mm	—	6.1 A	—			52	50.8	48.1	45.5	42.7	39.5			
2CDX 200/40	3.0 kW	25 / 40 mm	—	6.7 A	—			62.5	61.1	58	55.2	52.3	49			
2CDX 200/50	3.7 kW	25 / 40 mm	—	8.7 A	—			71.5	70.1	67	64.3	61.2	57.5			

Sectional Drawing

Model **2CDX**

No.	Description	Material	Qty.
1	Casing	304 S/Steel	1
3	Motor bracket	Aluminium (upto 1.5 kW) Cast Iron (2.2 kW & above)	1
4	Casing cover	304 S/Steel	1
6	Shaft with rotor	303 S/St (In contact with liquid)	1
7	Impeller	304 S/Steel	1
8	Impeller	304 S/Steel	1
9	Diffuser	304 S/Steel	1
11	Mechanical seal	Ceramic/Carbon/NBR	1
12	Motor frame with stator	-	1
13	Motor cover	Aluminium	1
14	Fan	Polyamide	1
15	Fan cover	Fe P04 (Gal)	1
16	Terminal block	-	1
17	Terminal box cover	ABS [1] Alum [2]	1
18	Splash ring	NBR	1
19	Pump side ball bearing	-	1
20	Fan side ball bearing	-	1
21	Adjusting ring	Steel C70	1
22	Tie rod	Fe 420 (Gal)	4
23	Capacitor [1]	-	1
24	Priming/Drain plug	304 S/Steel	2
26	O-Ring	NBR	1
27	O-Ring	NBR	1
32	Key	316 S/Steel	2
34	Impeller nut	304 S/Steel	1

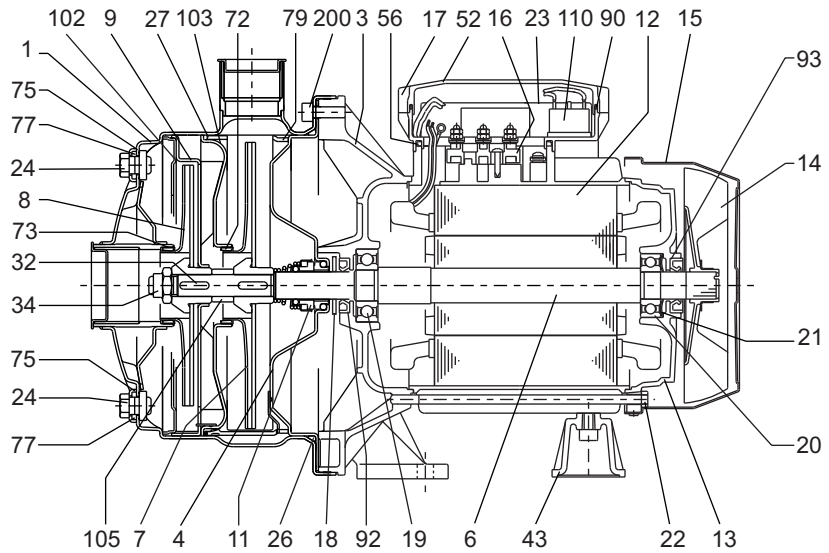

No.	Description	Material	Qty.	No.	Description	Material	Qty.
43	Motor support	Aluminium	1	90	Cover gasket [1]	NBR	1
52	Terminal box [1]	ABS	1	92	Lip seal	-	1
56	Box gasket	NBR	1	93	Lip seal	-	1
72	Casing ring	NBR	1	102	Suction cover	304 S/Steel	1
73	Casing ring	NBR	1	103	Conveyor cover	304 S/Steel	1
75	Washer	304 S/Steel	2	105	Sleeve	304 S/Steel	1
77	O-Ring	NBR	2	110	Protector [3]	-	1
79	Space diffuser	304 S/Steel	1	200	Screw	Stainless steel A2 UNI7323	8

1 - Only single phase 2 - Only three phase 3 - Only 1.1 & 1.5 kW single phase

Dimensions

Model **2CDX**

Units: mm unless otherwise specified

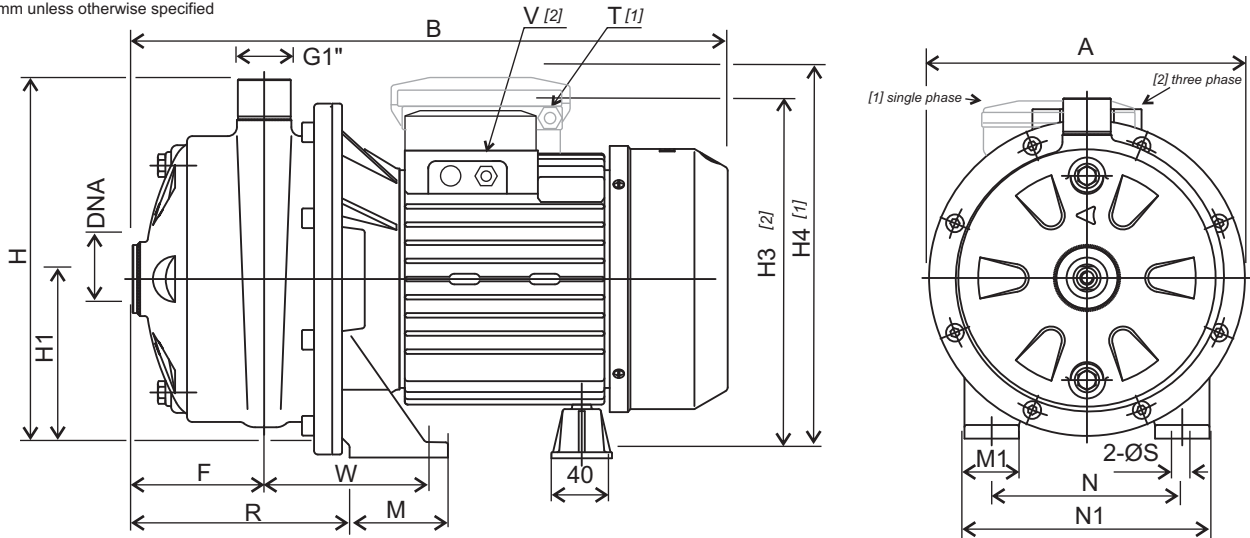

Pump Model 2CDXM 2CDX	Dimensions															Approx. Weight kg		
	A	B [1] [2]	F	H	H1	H3 [2]	H4 [1]	M	M1	N	N1	R	T [1]	V [2]	W		S	DNA (n)
70/10	208	355 / 354	87	229	106	207	216	50	38	120	160	143	PG 11	PG 11	93	9	G1¼	13
70/12	208	355 / 366	87	229	106	207	235	50	38	120	160	143	PG 13.5	PG 11	93	9	G1¼	14
70/15	232	396 / 382	89	250	118	237	249	55	40	140	180	142	PG 13.5	PG 11	95	9	G1¼	18
70/20	232	383 / 395	89	250	118	237	249	55	40	140	180	142	PG 13.5	PG 11	95	9	G1¼	19
120/15	208	396 / 382	89	229	106	225	237	55	40	140	180	142	PG 13.5	PG 11	95	9	G1¼	16
120/20	208	383 / 395	89	229	106	225	237	55	40	140	180	142	PG 13.5	PG 11	95	9	G1¼	18
120/30	232	- / 419	87	250	118	242	-	65	40	140	180	144	-	PG 13.5	109	9	G1¼	26
120/40	232	- / 458	87	250	118	242	-	65	40	140	180	144	-	PG 13.5	109	9	G1¼	28
200/30	208	- / 458	87	229	106	230	-	65	40	140	180	144	-	PG 13.5	109	9	G1½	26
200/40	232	- / 458	87	250	118	242	-	65	40	140	180	144	-	PG 13.5	109	9	G1½	28
200/50	232	- / 481	87	250	118	259	-	68	50	160	210	144	-	PG 16	109	12	G1½	36

Specifications subject to change without notice



EBARA PUMPS AUSTRALIA PTY. LTD.

Data Sheet
2CDX 13-03